

# Standard Carport Design

## CNI-017

Deviations from this design will require the submission of engineered plans.

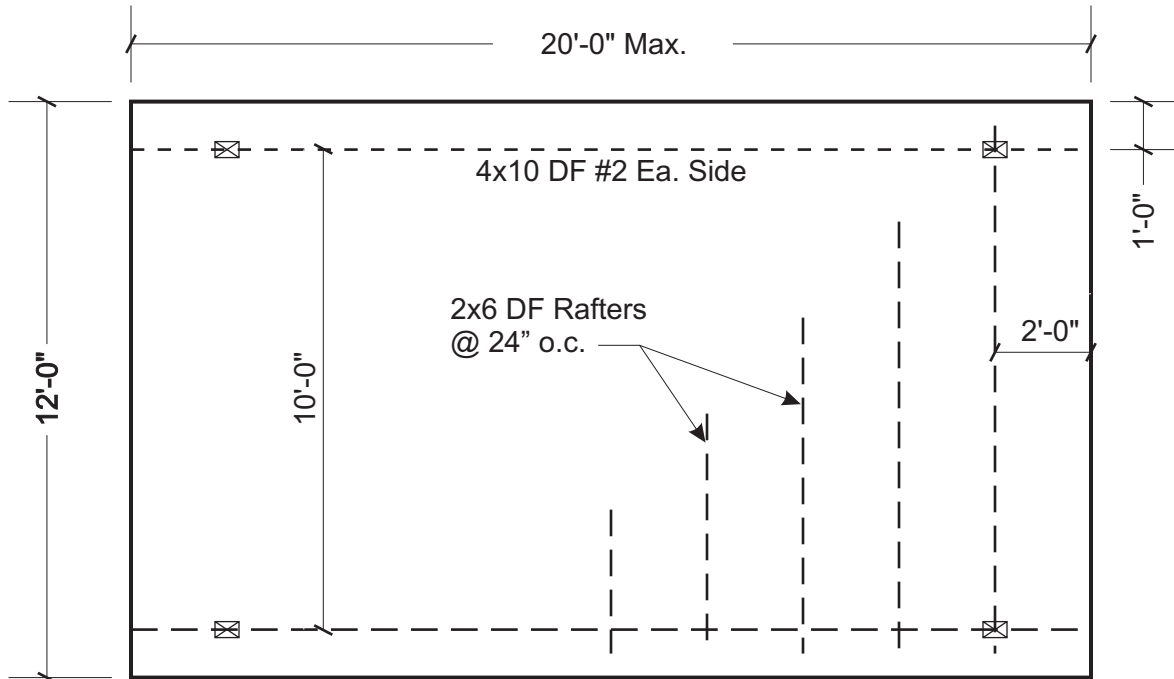

**Plan View**

NOTE:

PT = Pressure Treated

DF = Douglas Fir

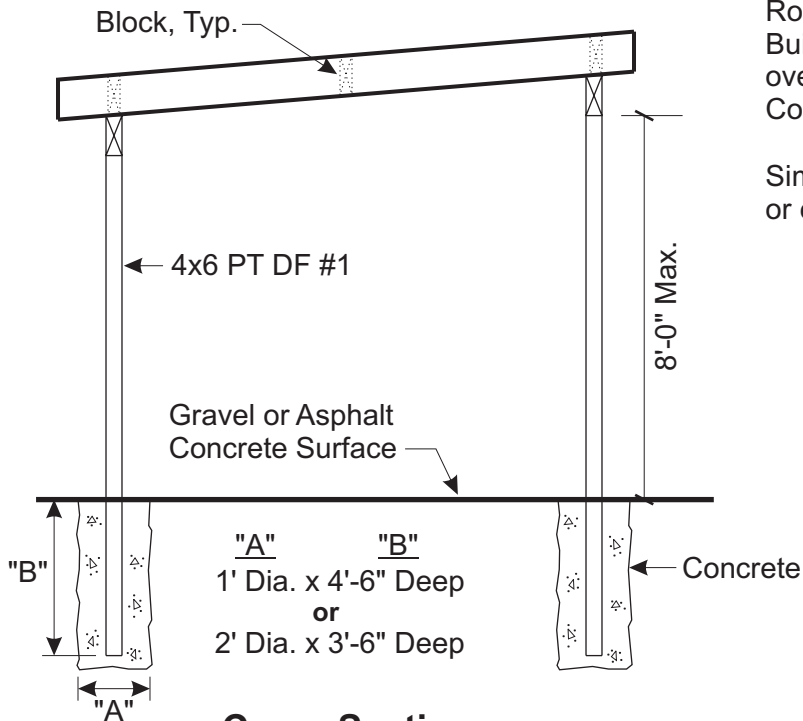

**Cross Section**

Roofing:

Built up Tar & Gravel  
over 5/8" plywood or  
Corrugated Metal

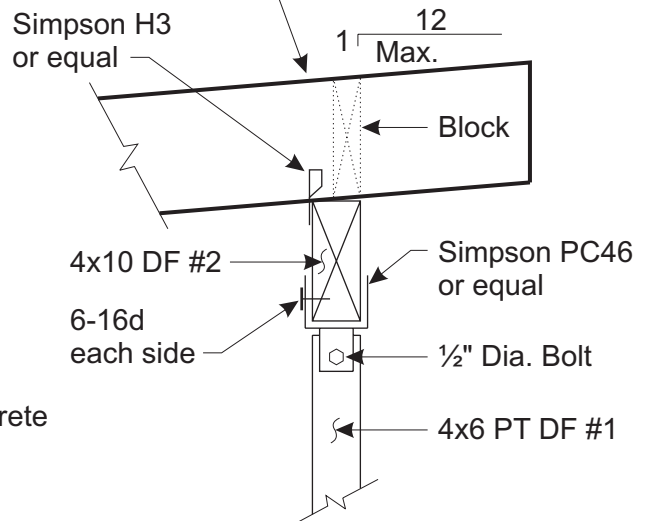

**Roof to Post Detail**

**Sonoma County Permit and Resource Management Department**

2550 Ventura Avenue ❖ Santa Rosa, CA ❖ 95403-2829 ❖ (707) 565-1900 ❖ Fax (707) 565-1103